

# PS SERIES

## Square Inductive Proximity Sensors

### ■ Features

- > Surge Protection □
- > Reverse Polarity Protection □
- > LED Output Indicator □
- > 2 Meter PVC Cable □
- > IP67 Environmental Protection □
- > All Plastic Body



### ■ Type

#### DC 3-Wire Switching 10 - 30V DC

Appearances	Model
12 square 	PS12-4DN
	PS12-4DP ※
	PS12-4DN2
	PS12-4DNU
	PS12-4DPU ※
17 square 	PS17-3DN
	PS17-3DP
	PS17-3DN2 ※
	PS17-5DN
	PS17-5DP
	PS17-5DNU
	PS17-5DPU
	PS17-5DN2U ※
	PS17-8DN
	PS17-8DP
PS17-8DPU	
20 square 	PS20-8DN
	PS20-8DP
	PS20-8DN2 ※
	PS20-8DNU
	PS20-8DPU

#### DC 3-Wire Switching 10 - 30 V DC

Appearances	Model
20 square 	PS20-8DN-F
	PS20-8DNU-F
	PS20-8DPU-F
25 square 	PS25-5DN
	PS25-5DP
	PS25-5DN2 ※
30 square 	PS30-10DN
	PS30-10DP
	PS30-10DN2 ※
	PS30-15DN
	PS30-15DP
	PS30-15DN2 ※
35 square 	PS35-10DN
	PS35-10DP
	PS35-10DN2 ※
	PS35-10DP2 ※
	PS35-10DNS
	PS35-10DPS
	PS35-10DN2S ※
	PS35-10DP2S ※
	PS35-15DN
	PS35-15DP
PS35-15DN2 ※	
PS35-15DP2 ※	
40 square 	PS40-20DN
	PS40-20DN2
	PS40-20DP
50 square 	PS50-30DN
	PS50-30DP
	PS50-30DN2 ※
	PS50-30DP2 ※

#### AC 2-Wire Switching 90 - 250V AC

Appearances	Model
25 square 	PS25-5AO
	PS25-5AC
30 square 	PS30-10AO
	PS30-10AC
	PS30-15AO
35 square 	PS35-10AO □
	PS35-10AC □
	PS35-10AOS □
	PS35-10ACS □
	PS35-15AO □
	PS35-15AC □
	PS35-15AOS □
	PS35-15ACS □
40 square 	PS40-20AO
	PS40-20AC

#### DC 2-Wire Switching 20 - 30V DC

Appearances	Model
17 square 	PST17-5DO
	PST17-5DC
17 square 	PST17-5DOU
	PST17-5DCU

## Specifications: DC 3-Wire Switching

Model	PS12-4DN PS12-4DP PS12-4DN2 PS12-4DNU PS12-4DPU PS12-4DN2U	PS17-3DN PS17-3DP PS17-3DN2	PS17-5DN PS17-5DP PS17-5DNU PS17-5DPU PS17-5DN2U	PS17-8DN PS17-8DP PS17-8DNU PS17-8DPU	PS20-8DN PS20-8DP PS20-8DN2 PS20-8DN-F PS20-8DNU PS20-8DPU PS20-8DNU-F PS20-8DPU-F	PS25-5DN PS25-5DP PS25-5DN2	PS30-10DN PS30-10DP PS30-10DN2	PS30-15DN PS30-15DP PS30-15DN2	PS35-10DN PS35-10DP PS35-10DN2 PS35-10DP2 PS35-10DPS PS35-10DP2S PS35-10DP2S	PS35-15DN PS35-15DP PS35-15DN2 PS35-15DP2 PS35-15DPS PS35-15DP2S PS35-15DP2S	PS40-20DN PS40-20DP PS40-20DN2	PS50-30DN PS50-30DP PS50-30DN2 PS50-30DP2
Detecting distance	4mm ±10%	3mm ±10%	5mm ±10%	8mm ±10%	8mm ±10%	5mm ±10%	10mm ±10%	15mm ±10%	10mm ±10%	15mm ±10%	20mm ±10%	30mm ±10%
Hysteresis	Max. 10% of detecting distance											
Standard detecting target	20×20×1mm (Iron)	18×18×1mm (Iron)	25×25×1mm (Iron)			30×30×1mm (Iron)	40×40×1mm (Iron)	45×45×1mm (Iron)	35×35×1mm (Iron)	45×45×1mm (Iron)	60×60×1mm (Iron)	90×90×1mm (Iron)
Setting distance	0 to 2.8	0 to 2.1	0 to 3.5	0 to 5.6		0 to 3.5	0 to 7	0 to 10.5	0 to 7	0 to 10.5	0 to 14	0 to 21
Power supply (Operating voltage)	12 to 24VDC (10 to 30VDC)											
Power consumption	Max. 10mA											
Response frequency	500Hz	700Hz	500Hz	200Hz	300Hz	350Hz	250Hz	100Hz	250Hz	100Hz	250Hz	50Hz
Residual voltage	Max. 1.5V											
Variation due to Temp. fluctuation	±10% Max. of detecting distance at +20°C within temperature range of -25 to +70°C											
Control output	Resistive load:200mA, Inductive load:100mA											
Insulation resistance	Min. 50M $\Omega$ (500VDC)											
Dielectric strength	1500VAC 50/60Hz for 1 minute											
Vibration	1mm amplitude at frequency of 10 to 55Hz in each of X,Y,Z directions for 2 hours											
Shock	500m $\text{ms}^2$ (50G) in X,Y,Z directions for 3 times											
Indicator	Operating indicator : red LED											
Operating temperature	-25 to +70°C (non-freezing condition)											
Storage temperature	-30 to +80°C (non-freezing condition)											
Ambient humidity	35 to 95% RH											
Protection circuit	Reverse polarity protection, surge protection circuit, overload & short-circuit protection(PS35, PS50 Series)											
Protection	IP67(IEC specification)											
Net Weight	About 62g	About 69g	About 71g	About 70g	About 66g	About 97g	About 183g	About 187g	About 145g	About 145g	About 248g	About 220g

## Specifications: AC 2-Wire Switching / DC 2-Wire Switching

Model	PS25-5AO PS25-5AC	PS30-10AO PS30-10AC	PS30-15AO PS30-15AC	PS35-10AO PS35-10AC PS35-10AOS PS35-10ACS	PS35-15AO PS35-15AC PS35-15AOS PS35-15ACS	PS40-20AO PS40-20AC	PST17-5DO PST17-5DC PST17-5DOU PST17-5DCU
Detecting distance	5mm ±10%	10mm ±10%	15mm ±10%	10mm ±10%	15mm ±10%	20mm ±10%	5mm ±10%
Hysteresis	Max. 10% of detecting distance						
Standard detecting target	30×30×1mm (Iron)	40×40×1mm (Iron)	45×45×1mm (Iron)	35×35×1mm (Iron)	45×45×1mm (Iron)	60×60×1mm (Iron)	25×25×1mm (Iron)
Setting distance	0 to 3.5	0 to 7	0 to 10.5	0 to 7	0 to 10.5	0 to 14	0 to 3.5
Power supply (Operating voltage)	110 to 220VAC (90 to 250VAC)						24VDC (20 to 30VDC)
Leakage current	Max. 2.5mA						Max. 0.9mA
Response frequency	20Hz						500Hz
Residual voltage	Max. 10V						Max. 7V
Variation due to Temp. fluctuation	±10% Max. of detecting distance at +20°C within temperature range of -25 to +70°C						
Control output	Resistive load:200mA, Inductive load:100mA						Resistive load:50mA, Inductive load:25mA
Insulation resistance	Min. 50M $\Omega$ (500VDC)						
Dielectric strength	1500VAC 50/60Hz for 1 minute						
Vibration	1mm amplitude at frequency of 10 to 55Hz in each of X,Y,Z directions for 2 hours						
Shock	500m $\text{ms}^2$ (50G) in X,Y,Z directions for 3 times						
Indicator	Operating indicator : red LED						
Operating temperature	-25 to +70°C (non-freezing condition)						
Storage temperature	-30 to +80°C (non-freezing condition)						
Ambient humidity	35 to 95% RH						
Protection circuit	surge protection circuit						
Protection	IP67(IEC specification)						
Weight	About 144g	About 183g	About 173g	About 135g	About 135g	About 254g	About 59g

\*The weight of above chart is net weight.

# PS SERIES

## Dimension

Unit:mm

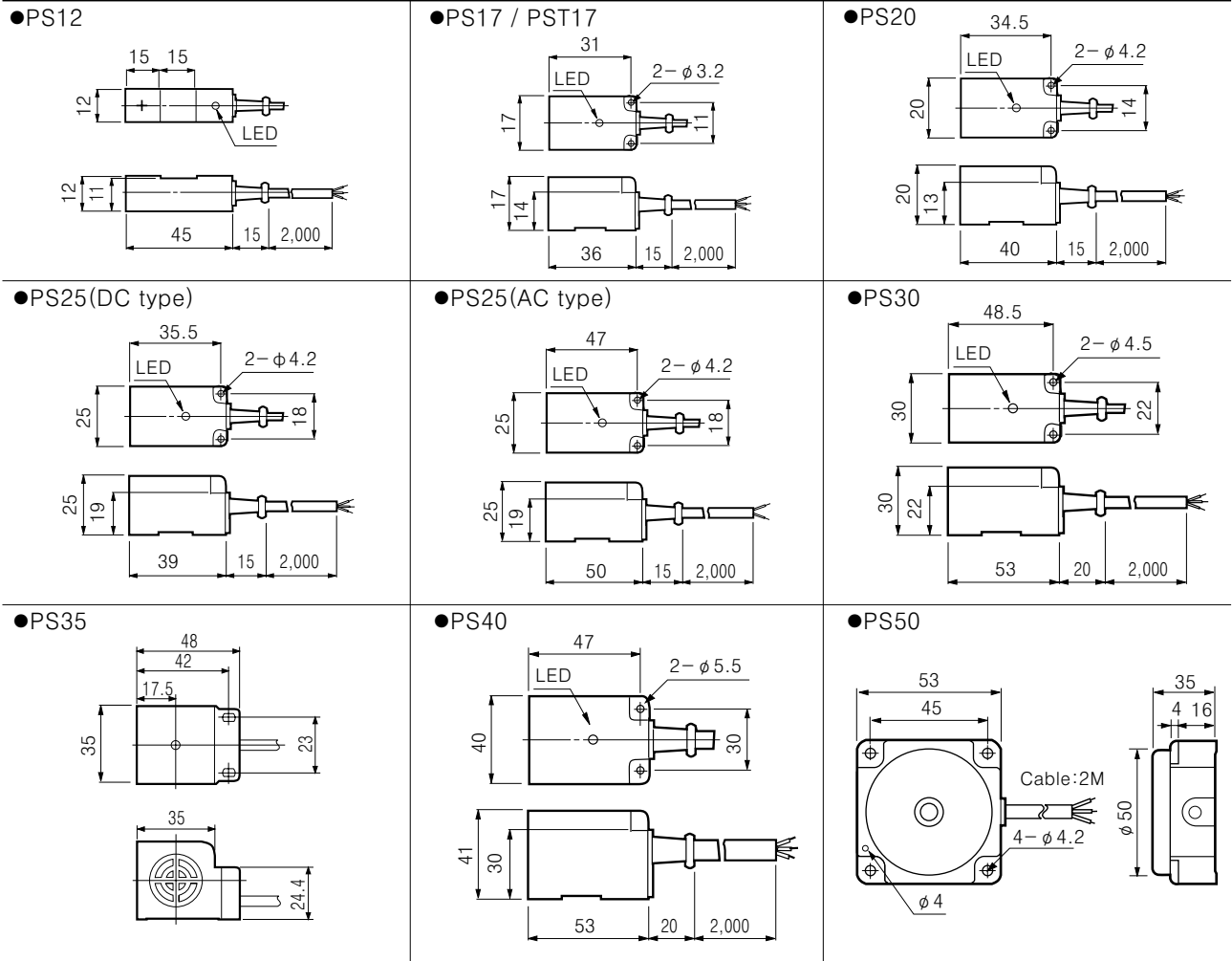

## Bracket dimension

Unit:mm

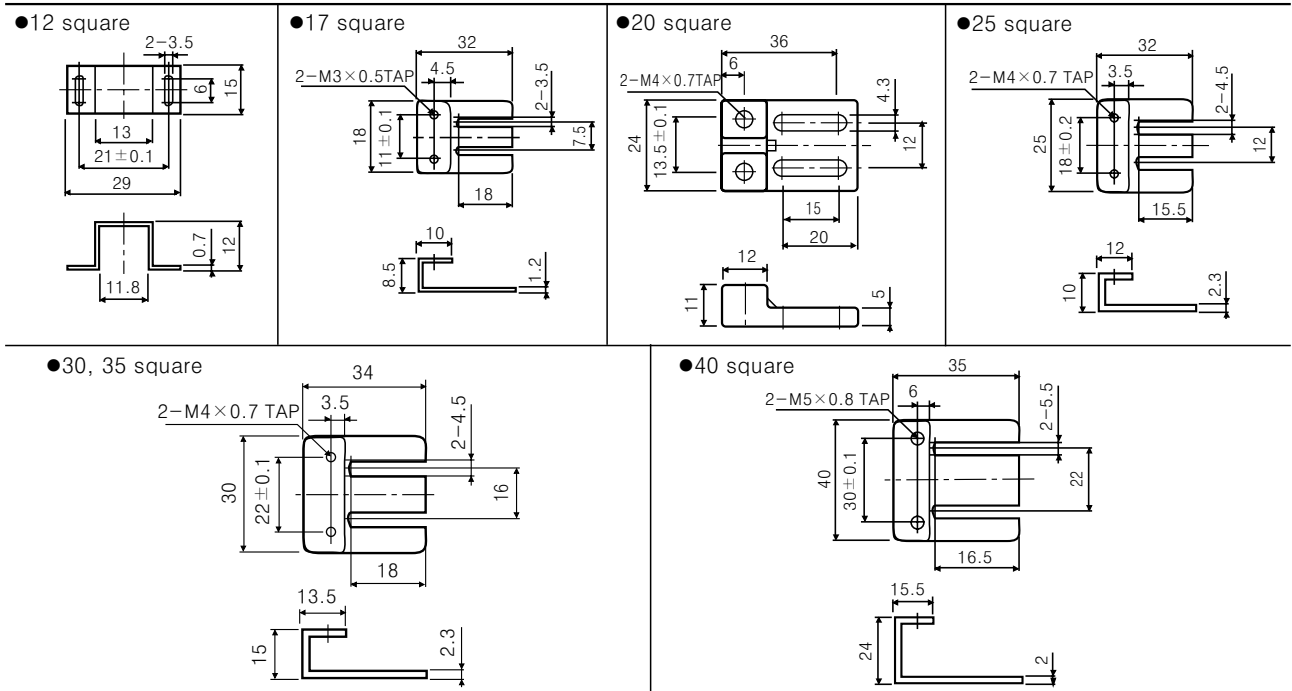

## Schematics / Operation

### DC 3-Wire Switching

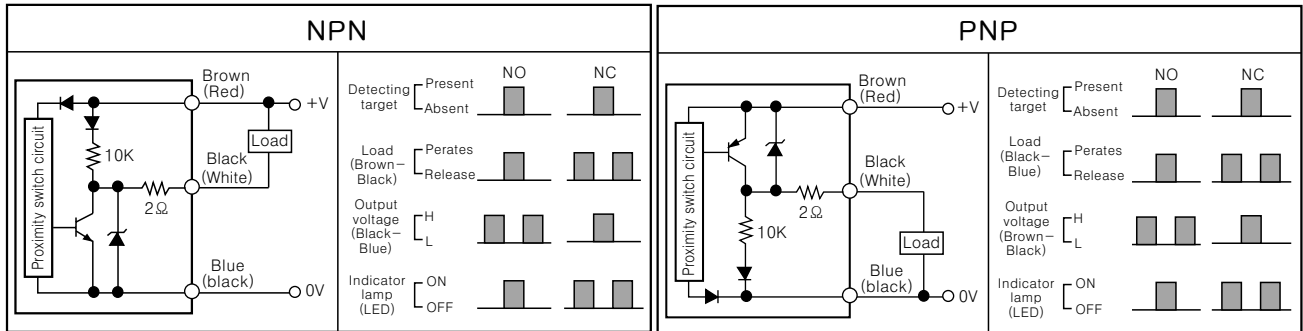

### AC 2-Wire Switching

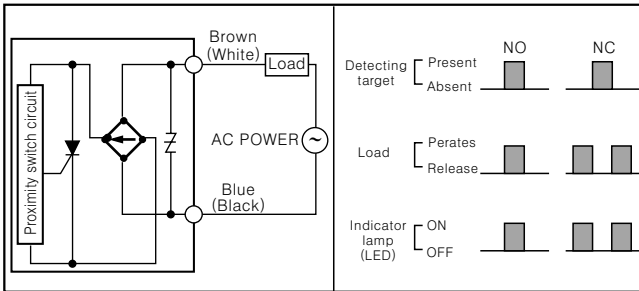

### DC 2-Wire Switching

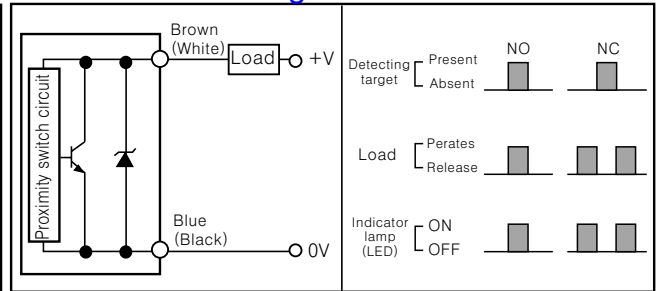

## Wiring Diagrams

### DC 3-Wire Switching

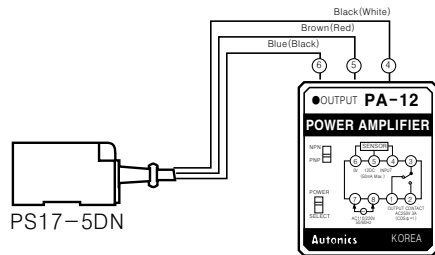
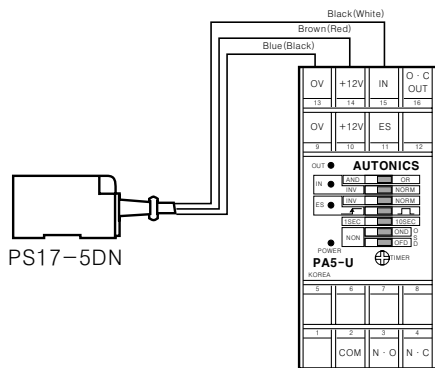

※PA-12 can be selected NPN or PNP by front slid switch.

### AC 2-Wire Switching

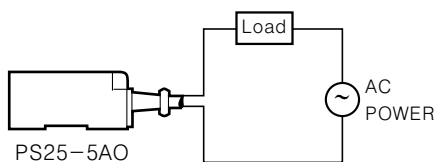

### DC 2-Wire Switching

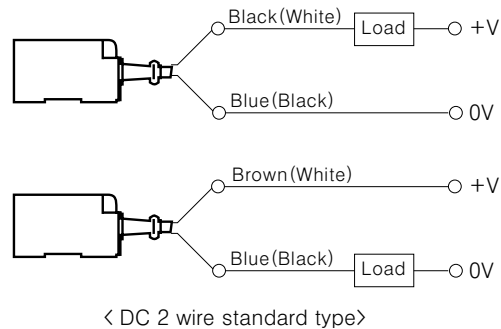

## CAUTION

The load must be connected.

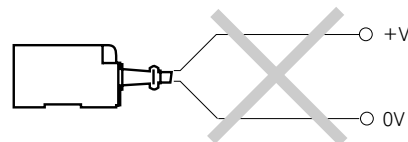

Do not connect both leads  directly to the power supply. A  properly rated load must be  connected in series with the  sensor as shown above in the  wiring diagrams